

# MT-APN16 MEDICAL GAS AND VACUUM ALARM PANEL



## INSTALLATION & OPERATING MANUAL

PO Box 159  
Edgemead 7407  
Cape Town RSA  
Tel (27) (021) 558-7040  
Fax (27) (021) 558-0371  
[gas@mediteksystems.co.za](mailto:gas@mediteksystems.co.za)  
[www.mediteksystems.co.za](http://www.mediteksystems.co.za)

  
**meditek**  
systems

# **INDEX**

# **PAGE**

<b>1. DESCRIPTION</b>	<b>1</b>
<b>2. FEATURES</b>	<b>2</b>
<b>3. MASTER CONFIGURATION</b>	<b>4</b>
<b>4. SLAVE CONFIGURATION (WITH INPUTS)</b>	<b>6</b>
<b>5. SLAVE CONFIGURATION (NO INPUTS)</b>	<b>8</b>
<b>6. INSTALLATION INSTRUCTIONS</b>	<b>10</b>
<b>7. SCHEMATIC DIAGRAM</b>	<b>13</b>
<b>8. CONNECTION DIAGRAMS</b>	
(A) MASTER PANEL	<b>14</b>
(B) SLAVE PANEL (WITH INPUTS)	<b>15</b>
(C) SLAVE PANEL	<b>16</b>
(D) PC COMMUNICATIONS	<b>17</b>
(E) POWER SUPPLY	<b>18</b>
<b>9. PCB LAYOUT</b>	<b>19</b>
<b>10. SPECIFICATIONS</b>	
(A) ELECTRICAL/ ELECTRONIC SPECS	<b>20</b>
(B) FLUSH MOUNT DIMENSIONS	<b>21</b>
(C) SURFACE MOUNT DIMENSIONS	<b>22</b>
(D) FRONT FACIA LAYOUT	<b>23</b>

# **DESCRIPTION**

Housed in a weather-proof enclosure with a transparent hinged lid ensures that the system is capable of indoor or outdoor operation. The fascia depicts each monitored point with an engraved colour symbol and two LED's (light emitting diode), indicating NORMAL and ALARM conditions.

The status of 16 inputs (switches) can be monitored. These inputs can be individually configured for 'normally open' or 'normally closed' switches. Any voltage-free contact switch can be used including pressure, magnetic, proximity and PIR switches. 4 to 20ma signals can also be accommodated using a converter.

The input switches are connected to the Master panel which then transmits the status of these switches to the Slave (mimic) panel/s. In the occurrence of one or more switches being a long distance from the Master, but close to a Slave panel, these switches can be connected to that Slave panel. This Slave panel will then become a 'SLAVE PANEL WITH INPUTS' and must be configured as such.

Using 'normally closed' switches ensure a 'Fail Safe' condition with the alarm being activated should the cable be cut or damaged. This system can also be coupled to other existing alarm systems via our interface module.

During an alarm condition an audible buzzer is activated which can be manually muted. The visual alarm LED's will however continue to indicate a fault until such time as the fault's rectified. The audible alarm is re-activated should an additional alarm condition occur.

A maximum of 15 Slave (mimic) panels can be placed up to 1 Km from the Master panel, linked via a serial interface 2-core cable. All panels have TEST and MUTE buttons to test all LED's and to mute the buzzer during alarm conditions.

Computer 'Link-Up' is possible using either a RS232 or RS485 interface. The computer software allows OSD (On Screen Display) of the Alarm Network with usage and fault logging statistics.

Operating from a standard 230V ac supply, the system uses a dual 5V DC power supply to monitor the input switches and to power the motherboard.

# **FEATURES**

## **OPERATION**

- 1) Master and Slave panels are identical ensuring easy replacement.
- 2) Test and Mute on all panels.
- 3) Maximum of 38 hi-bright LED's per panel indicate operating status and functions.
- 4) 5V DC audible alarm buzzer provided on all panels.
- 5) On-board configuration facilities for selecting various modes of operation (eg Master/Slave, Buzzer On/Off, Slave ID No's, Fault LED's Flash On/Off, Switch type, Services enable/disable etc).
- 6) On-board microprocessor 'Watch-Dog' circuitry.
- 7) Slaves reflect current status of all inputs.
- 8) Two modes of alarm condition indication:
  - i) Dual warning LED's – Green for normal and flashing Red for alarm condition.
  - ii) Single Warning LED – Green disabled and red continuously for alarm condition.
- 9) Audible alarm buzzer can be enabled or disabled at each panel.
- 10) Audible alarm is re-activated on a new alarm condition if already muted.
- 11) All panels on the network are muted when MUTE is pressed on the Master panel.
- 12) Pressing the TEST button will activate the buzzer and test all LED's.
- 13) Weather-proof, rustproof plastic enclosure for internal or external use.
- 14) Removable inspection cover for access to front panel buttons, buzzer and comms terminals.
- 15) Light-weight enclosure with hinged transparent door and mounting holes for easy installation.
- 16) Colour coded mimic pictures on the fascia indicate each monitoring point and description.
- 17) Special function mimic pictures can be manufactured to end-user's specifications for use on the fascia.
- 18) 6 Status LED facilities. (Power, Network Error, Mains Fail, uP Reset, Network Tx, Rx, and PC Tx).

# **FEATURES**

(CONTINUED)

## **INPUT SWITCHES**

- 1) The status of 16 inputs can be monitored. Each of these can be individually configured for 'Normally Open' or 'normally closed' switches.
- 2) Failsafe operation. Alarm activated on the cable being cut or damaged while using 'Normally Closed' switches.
- 3) Optically isolated inputs to protect against induced voltages on input lines.
- 4) Input switches can be connected to the Master panel or any Slave panel (With Inputs).

## **COMMUNICATIONS**

- 1) Switched relay output for connection to other external devices. Mutable/Non-Mutable selection jumper.
- 2) Computer link-up software to monitor Alarm Network and provide stats with OSD.
- 3) Two-wire, half-duplex, RS485 party-line interface for Master/Slave communication up to 1Km apart.
- 4) RS485 or RS232 Serial interface for Computer link-up.
- 5) Master panel monitors the communication line and indicates a fault should any Slave with inputs not respond when polled.
- 6) Slave panel indicates a fault should the transmission from the Master not be received thus warning of a network failure.
- 7) Slave (with Inputs) panel will indicate a comms error if not polled by the Master.
- 8) Maximum of 15 Slaves can be connected to the Master.
- 9) Master to Slave communications requires only 0.22 Mylar screen 2 core cable.

## **POWER SUPPLY**

- 1) All panels have a dual 5V DC power supply with 230V or 110V ac inputs.
- 2) 12V DC battery charger on-board.
- 3) Battery back-up with on-board battery charger. (Batteries optional).
- 4) Built in mains failure alarm.

*NOTE: Features are subject to change without notice.*

# MASTER CONFIGURATION

## MONITORING POINT SWITCHES (SW 1 AND SW 2)

**SW1** and **SW2** are DIP (Dual In-line Pin) switches located on the PC board (See Master Panel Connections-Page 14). These are used to configure the type of switches used at the monitoring points. These can be either 'Normally Open' or 'Normally closed' switches under normal conditions.

**SW 1** - numbers 1 to 8 represent monitoring points 1 to 8.

**SW 2** - numbers 1 to 8 represent monitoring points 9 to 16.

Set each DIP switch to represent the type of switch at the corresponding monitoring point.

ON - 'Normally Closed' switch. (Opens on fault)  
OFF- 'Normally Open' switch. (Closes on fault)

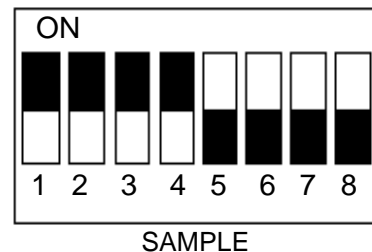

*NOTE: ALL UNUSED DIP SWITCHES MUST BE SET TO OFF.*

## PANEL IDENTITY (SW 3)

**SW 3** is a DIP (Dual In-line Pin) switch used to configure the number of Slaves with inputs on the network. This DIP switch is normally factory set and requires no adjustment

NOTE: If there are NO SLAVES with inputs, then all switches are set to ON.



1 Slave with inputs.

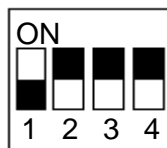

2 Slaves with inputs

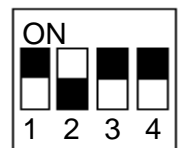

3 Slaves with inputs



4 Slaves with inputs



# MASTER CONFIGURATION

(CONTINUED)

## FUNCTION MODE (SW 4)

No 1 is the Buzzer Mode.  
No 2 is the Alarm Indication Mode.  
No 3 is the Master/Slave Mode.  
No 4 is the Mute Time Mode

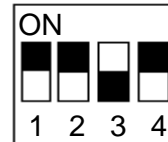

DEFAULT

## BUZZER MODE

When set to ON the buzzer is ENABLED.  
When set to OFF the buzzer is DISABLED.

BUZZER ON

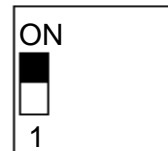

BUZZER OFF



## ALARM INDICATION MODE

When set to ON the Green LED shows for 'Normal' and the Red LED flashes for 'FAULT'.

MODE 1

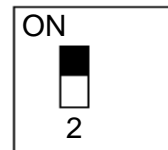

MODE 2

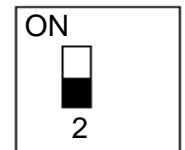

When set to OFF the Green LED is always 'DISABLED' and the Red LED flashes for 'FAULT' only.

## MASTER/SLAVE SELECTION

This configures a panel as a Master or a Slave.  
As a Master this is always set to ON.

MASTER

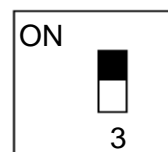

## MUTE TIME SELECTION

When set to ON the Mute time is set to 30 Min.  
When set to OFF the Mute time is set to 15 Min.  
After this period the panel gives a reminder buzz

30 MIN



15 MIN

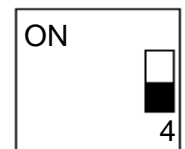

# SLAVE CONFIGURATION (WITH INPUTS)

## MONITORING POINT SWITCHES (SW 1 AND SW 2)

**SW 1** and **SW 2** are DIP (Dual In-line Pin) switches located on the PC board (See Slave [with inputs] Connections - Page 15). These are used to configure the type of switches used at the monitoring points. These can be either 'Normally Open' or 'Normally Closed' switches under normal conditions.

**SW 1** numbers 1 to 8 represent-monitoring points 1 to 8.  
**SW 2** numbers 1 to 8 represent-monitoring points 9 to 16.

Set each DIP switch to represent the type of switch used at the corresponding input.

ON - 'Normally Closed' switch. (Opens on fault)  
OFF- 'Normally Open' switch. (Closes on fault).

*NOTE: All unused DIP switches must be set to OFF.*



SAMPLE

## PANEL IDENTITY (SW 3)

**SW 1** is a DIP (Dual In-line Pin) used to configure the Slave ID on the network. Every Slave with inputs has a unique ID. This DIP switch is normally factory set and requires no adjustment.

Slave 1 with inputs.



Slave 2 with inputs.

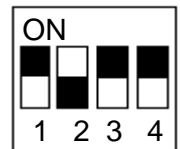

Slave 3 with inputs.



Slave 4 with inputs.

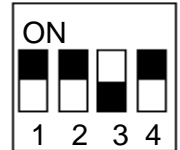

# SLAVE CONFIGURATION (WITH INPUTS)

(CONTINUED)

## FUNCTION MODE (SW 4)

No 1 is the Buzzer Mode.  
No 2 is the Alarm Indication Mode  
No 3 is the Master/Slave Mode.  
No 4 is the Mute Time Mode.

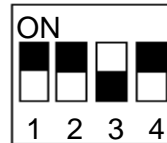

DEFAULT

## BUZZER MODE

When set to ON the buzzer is ENABLED.  
When set to OFF the buzzer is DISABLED.

BUZZER ON

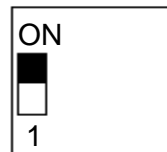

BUZZER OFF

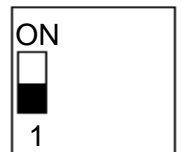

## ALARM INDICATION MODE

When set to ON the Green LED shows for 'NORMAL' and the Red LED flashes for 'FAULT'.

When set to OFF the Green LED is always disabled and the Red LED is on for 'FAULT' only.

MODE 1

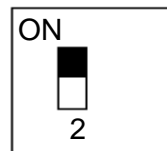

MODE 2

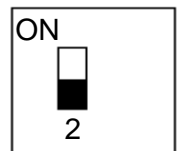

## MASTER/SLAVE SELECTION

This configures the panel as a Master or a Slave.  
As a Slave this is always OFF.

SLAVE (INPUT)

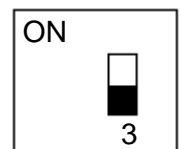

## MUTE TIME SELECTION

When set to ON the mute time is set to 30 Min.  
When set to OFF the mute time is set to 15 Min.  
After this period the panel gives a reminder buzz.

30 MIN



15 MIN

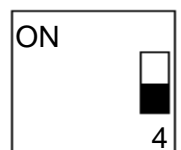

# SLAVE CONFIGURATION (NO INPUTS)

## MONITORING POINT SWITCHES (SW 1 AND SW 2)

**SW 1** and **SW 2** are DIP (Dual In-line Pin) switches located on the PC board (See Slave Panel Connections – Page 16). These are used to 'ENABLE' or 'DISABLE' the individual alarm inputs ie: when a particular service be disabled, the panel will ignore any alarm condition relating to that service.

**SW 1** - numbers 1 to 8 represent monitoring points 1 to 8.

**SW 2** - numbers 1 to 8 represent monitoring points 9 to 16.

Set each DIP switch to ENABLE or DISABLE the corresponding service. Normally all services are enabled.

ON – ENABLED.

OFF – DISABLED (Will ignore alarm condition).

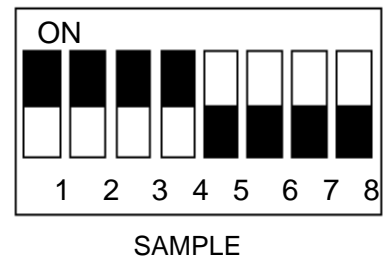

NOTE: ALL UNUSED DIP SWITCHES MUST BE SET TO OFF.

## PANEL IDENTITY (SW 3)

**SW 3** is a DIP (Dual In-line Pin) switch used to configure the Slave ID on the network.

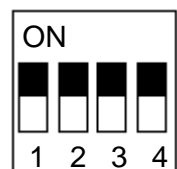

NOTE: AS THIS SLAVE HAS NO INPUTS, ALL SWITCHES ARE SET TO ON.

# SLAVE CONFIGURATION (NO INPUTS)

(CONTINUED)

## FUNCTION MODE (SW 4)

No 1 is the Buzzer Mode.  
No 2 is the Alarm Indication Mode.  
No 3 is the Master/Slave Mode.  
No 4 is the Mute Time Mode.

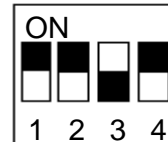

DEFAULT

## BUZZER MODE

When set to ON the buzzer is ENABLED.  
When set to OFF the buzzer is DISABLED.

BUZZER ON

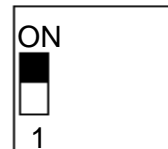

BUZZER OFF

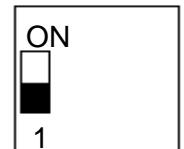

## ALARM INDICATION MODE

When set to **ON** the Green LED shows for 'NORMAL' and the Red LED flashes for 'FAULT'.

When set to **OFF** the Green LED is 'DISABLED' and the Red LED is on for 'FAULT' only.

MODE 1

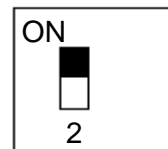

MODE 2



## MASTER/SLAVE SELECTION

This configures the panel as a Master or Slave.  
As a Slave this is always set to OFF.

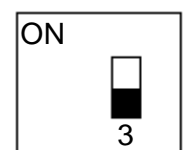

## MUTE TIME SELECTION

When set to **ON** the Mute time is set to 30 Min.  
When set to **OFF** the Mute time is set to 15 Min.  
After this period the panel gives a reminder buzz.

30 MIN



15 MIN

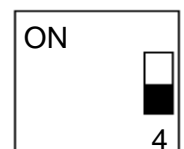

# INSTALLATION INSTRUCTIONS

## MOUNTING

Open the hinged door and carefully remove the screws holding the fascia. Remove the fascia plate. Remove the plastic hole cover situated at the top in the middle of the panel. Hold the panel over the required mounting position and mark.

Once secured, remove the bottom inspection cover and mark the corner mounting position. Tighten all mounting screws and replace inspection cover and fascia.

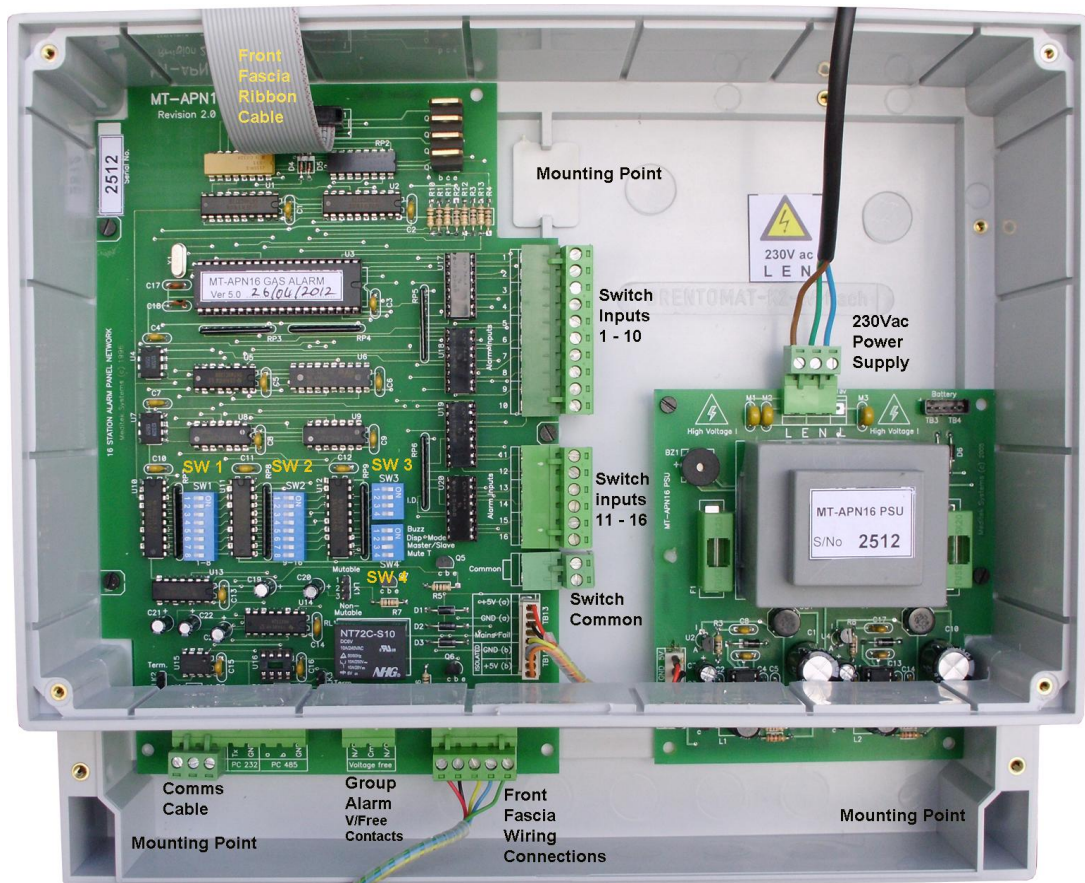

## SWITCHES

Connect one side of all the switches (1-16) to COMMON.  
(See Master Panel Instructions- Page 14).

Connect the other side of the switch to the connector as shown in the key.

# INSTALLATION INSTRUCTIONS (CONTINUED)

## COMMS CABLE

If the system incorporates Slave panel/s, communications between the Master and these Slave(s) is via a 2-core comms cable. Connect Gnd, A and B of terminal TB15 on the Master to terminal TB15 on the Slave panel(s). (See Diagrams- Pages 14, 15 & 16).

## COMMUNICATIONS PROBLEMS.

In case of unreliable communications, as a result of electrical noise, terminating resistors should be connected on TWO of the panels in the network. This is achieved by placing a jumper across link LK2 (located on the PC board) on the panels at the “ends” of the network. The ‘first’ and ‘last’ panels can generally be identified as the panels with only one comms cable connected to them. ie: those panels at the ‘END OF THE LINE’.

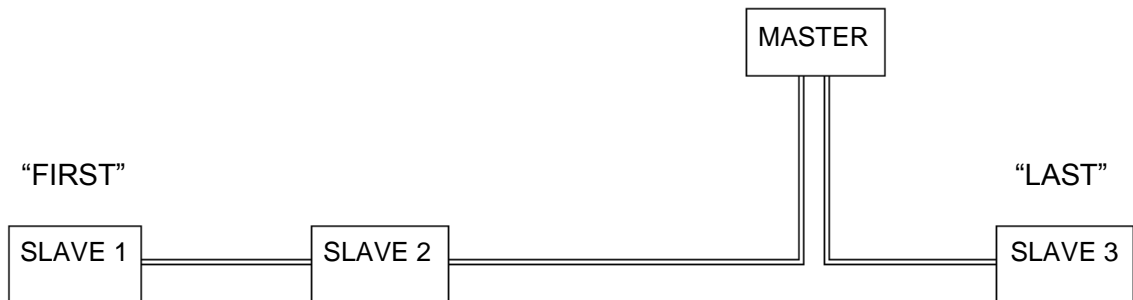

Place the link across LK2 to connect the terminating resistors.  
(See Diagrams- Pages 14, 15 & 16).

NOTE: ONLY THE ‘First’ AND ‘Last’ PANELS MUST BE TERMINATED!

## POWER SUPPLY

The system requires a 230V ac mains supply. Connect the mains supply to the PSU (Power Supply Unit) on the Master and Slave panels. (See Power Supply Connections- Page 18).

The PSU supplies a dual 5V DC for the main PCB and for the isolated inputs. Optional rechargeable 9,6 to 12V batteries can be connected to provide power in the event of a power failure. The back-up time of these batteries is approx 30 Min.

This 230V ac supply should be a dedicated line without any other equipment connected to it to ensure a stable and constant supply voltage.

# **INSTALLATION INSTRUCTIONS**

(CONTINUED)

## **PC (Computer) LINK**

If the computer link is required, a cable must be connected between the Master and the PC. This can be achieved by using one of two methods. The system has two 'PORTS' which can be used for the link.

The RS232 Serial Port is used if the distance between the Master and the PC is short. (Typically less than 30 meters.) This PORT is more susceptible to electrical noise and should not be used in noisy environments. Connect the PC Serial to TB16 (See PC Communications Connections - Page 17).

The RS485 Serial Port is used over longer distances. When using this port a RS485-RS232 converter is required. This device forms a link between the cable from the Master and the Computer Serial Port. (See Schematic Diagram - Page 13).

## **PC (Computer) SOFTWARE**

Install the software distributed on the CD into the drive and typing

D: \INSTALL

The program will install itself on the Hard Disk and prompt you for relevant information.

This software program will enable you to use a PC as an additional 'SLAVE'. It will reflect the latest status of the alarm network as well as log all changes to the status with a date and time stamp. This allows for statistical reporting on the entire gas installation.

## **EXTERNAL RELAY**

This relay makes provision for the connection of external devices to the alarm network such as sirens, buzzers, lights and other alarm systems. The relay's voltage-free outputs (TB10) include Normally Open, Normally Closed and Common Connections. It is activated on any alarm condition with a maximum load current of 1.5A at 230V ac or 3A at 24 V DC.

There are two operating modes for this relay output. They are 'Mutable' and 'Non-Mutable'. This mode is changed using LK1. Closing pins 1 & 2 set 'Mutable' mode and closing pins 2 & 3 set 'Non-Mutable' mode. (See Diagrams- Pages 14, 15 & 16).

# SCHEMATIC DIAGRAM

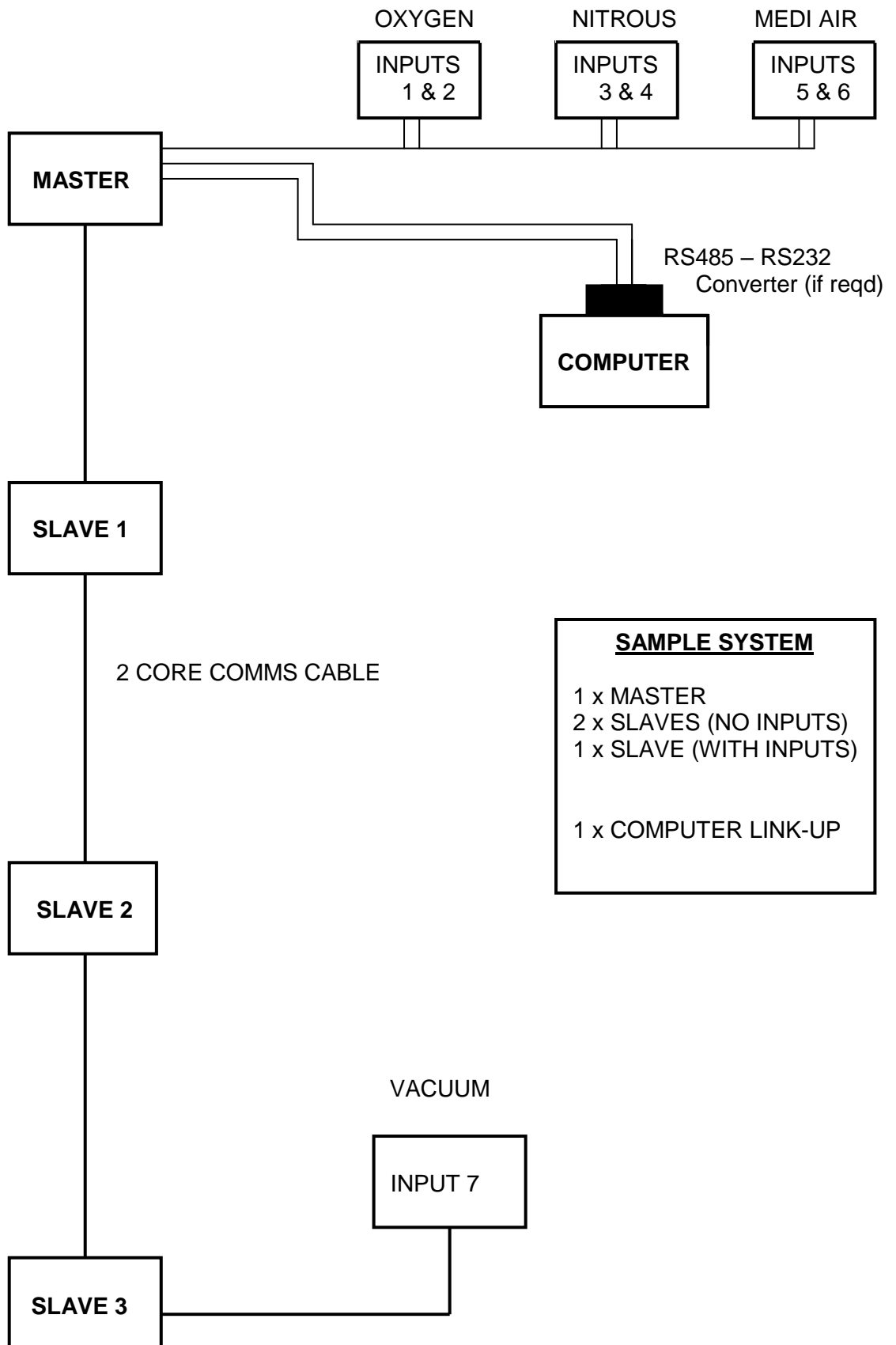

# Sample Configuration

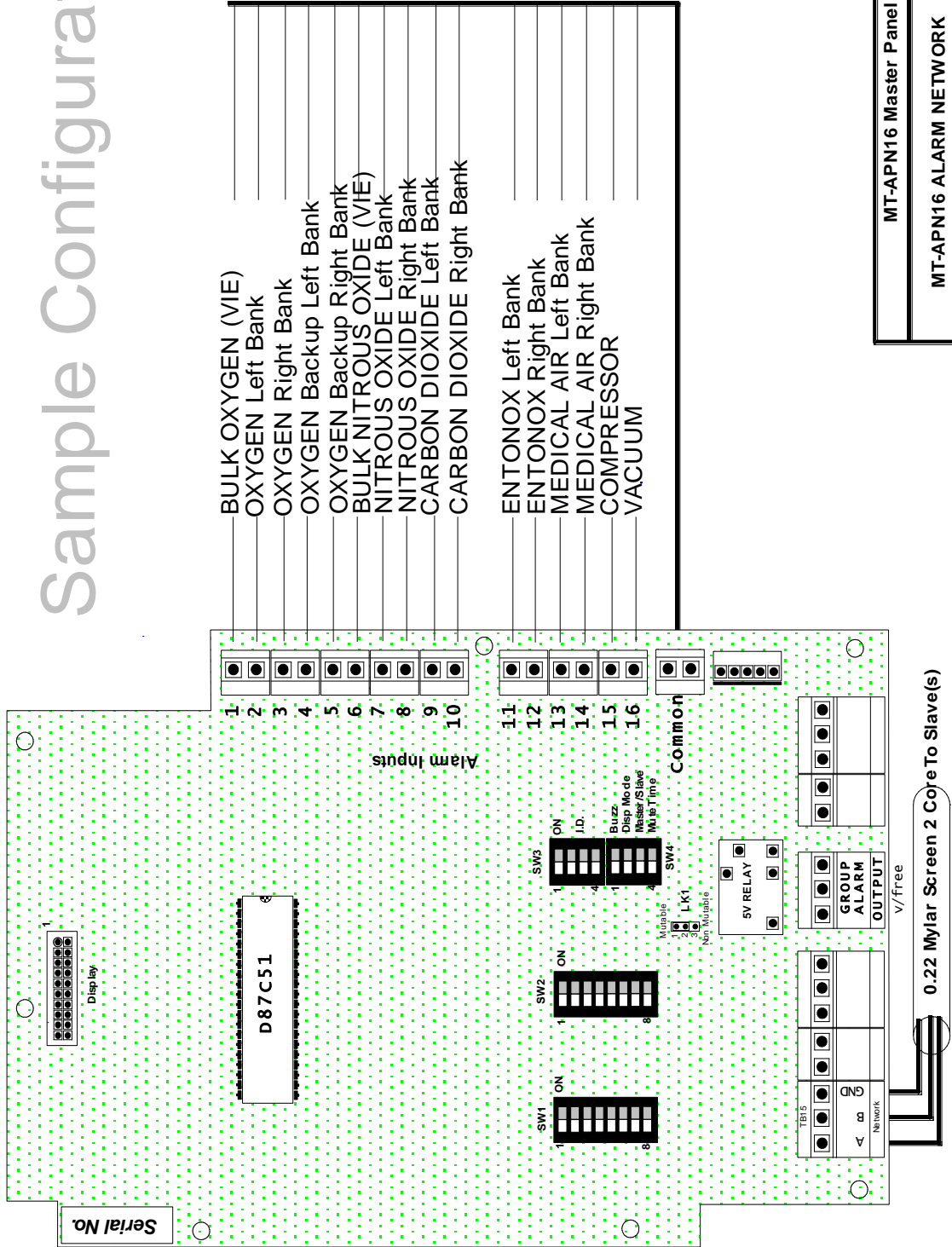

MT-APN16 Master Panel Connections	
MT-APN16 ALARM NETWORK	26 / 06 / 2001

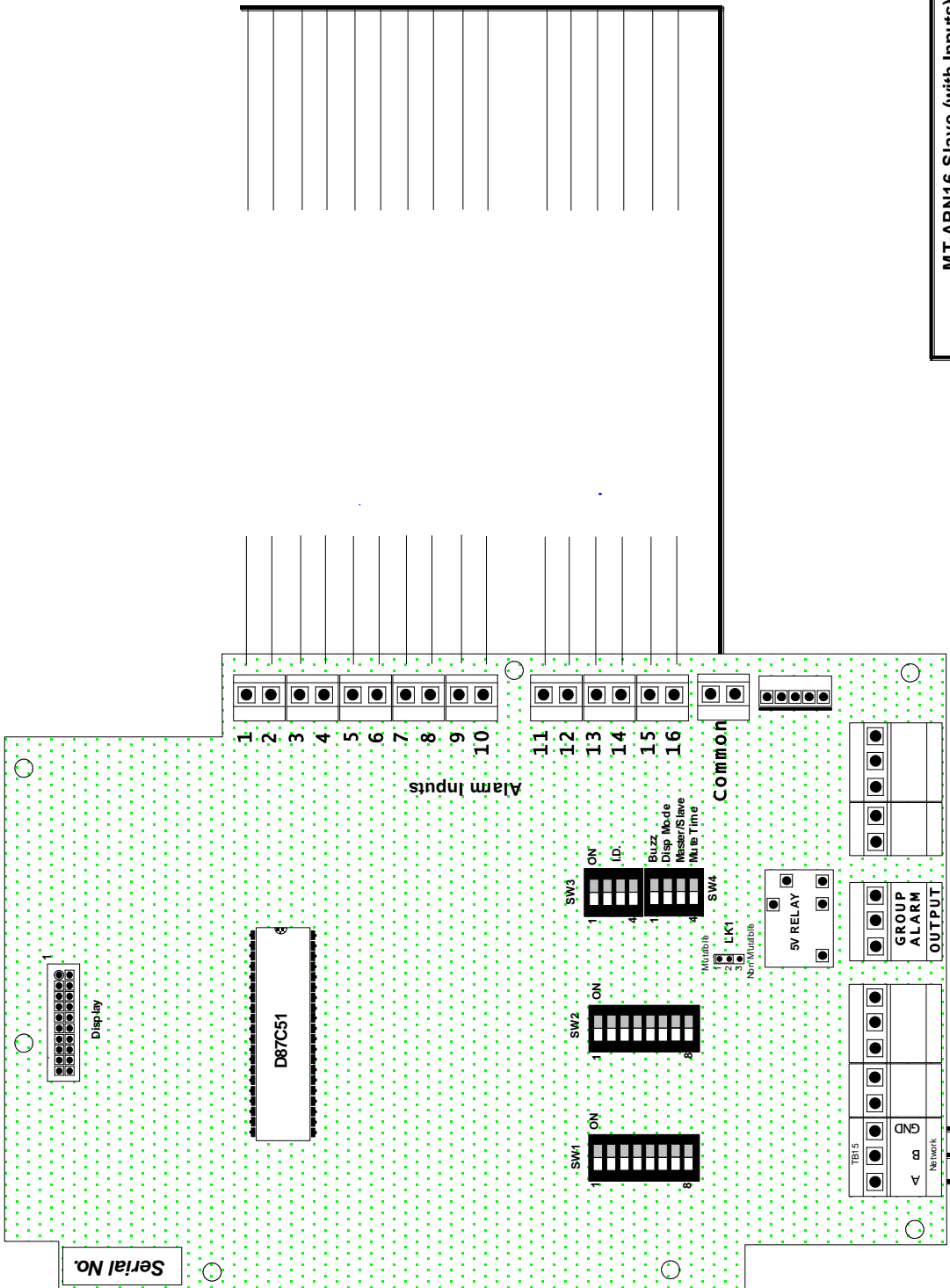

MT-APN16 Slave (with Inputs) Panel Connections
MT-APN16 ALARM NETWORK
28 / 06 / 2001

# DIP SWITCH SETTINGS

## SW1 (1-8) REPRESENTING INPUTS 1 - 8

- ON - ALARM ENABLED
- OFF - ALARM DISABLED

## SW2 (1-8) REPRESENTING INPUTS 9 - 16

- ON - ALARM ENABLED
- OFF - ALARM DISABLED

## SW3 (1-4)

SLAVE I.D. See Page 8

## SW4 (1-4) MODE SETTINGS

- 1 - BUZZER ON / OFF
- 2 - ON :Normal & Fault LEDs / OFF - Fault LEDs (
- 3 - OFF (Slave)
- 4 - MUTE TIME (15 / 30 Min)

MT-APN16 Slave Panel Connections
MT-APN16 ALARM NETWORK
28 / 06 / 2001

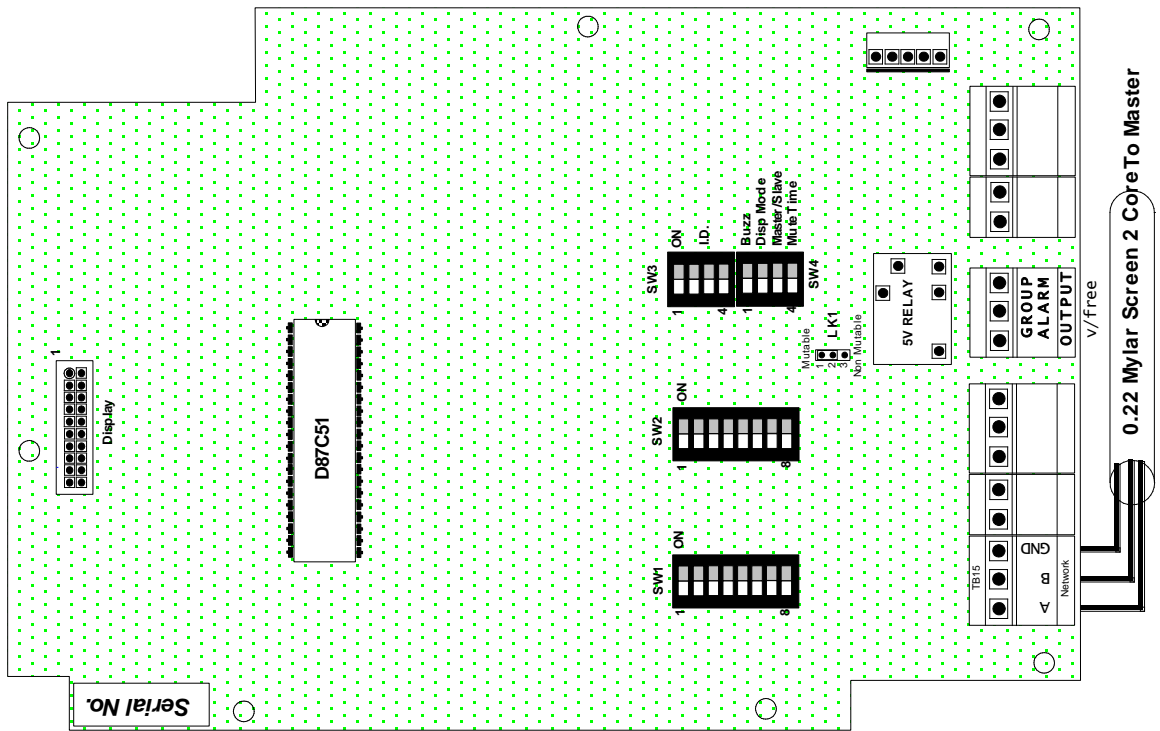

# PC COMMUNICATIONS LINK

## OPTION 1 ( < 30m )

This option utilizes the RS232 port (TB16).

Connect the Serial Cable between the Serial Port on the computer and TB16 (Tx & GND)

This serial cable may be purchased from Meditek Sys

## OPTION 2 ( > 30m )

This option utilizes the RS485 port (TB17)

Using the RS-485 port requires the use of a RS485 to converter. This converter is connected to the compute serial port. See SCHEMATIC DIAGRAM Page 13.

Connect the Serial Cable from the RS485 to RS232 cc on the computer to TB17 (a, b & GND).

This Serial Cable & the RS485 to RS232 converter ma purchased from Meditek Systems.

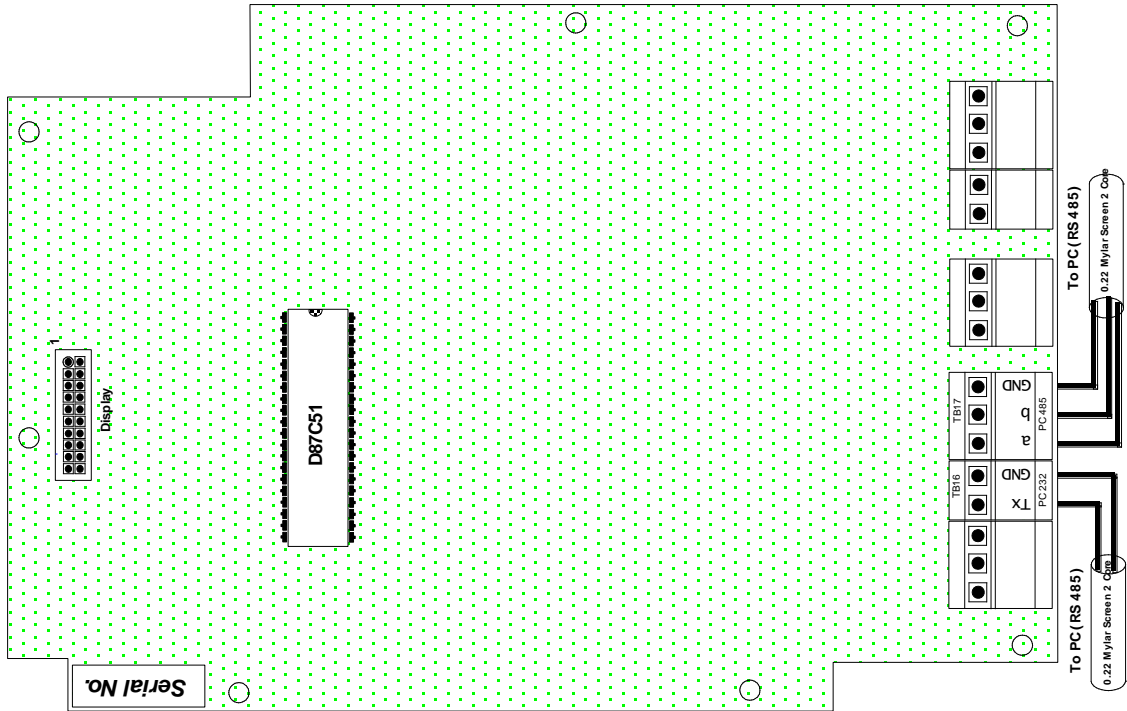

MT-APN16 PC Communications Connections
MT-APN16 ALARM NETWORK
28 / 06 / 200

**MT-APN16 Power Connections**

---

**MT-APN16 ALARM NETWORK**

---

**28 / 06 / 2001**

For alternative power supply input configurations, please contact Meditek Systems.

**220V ac**

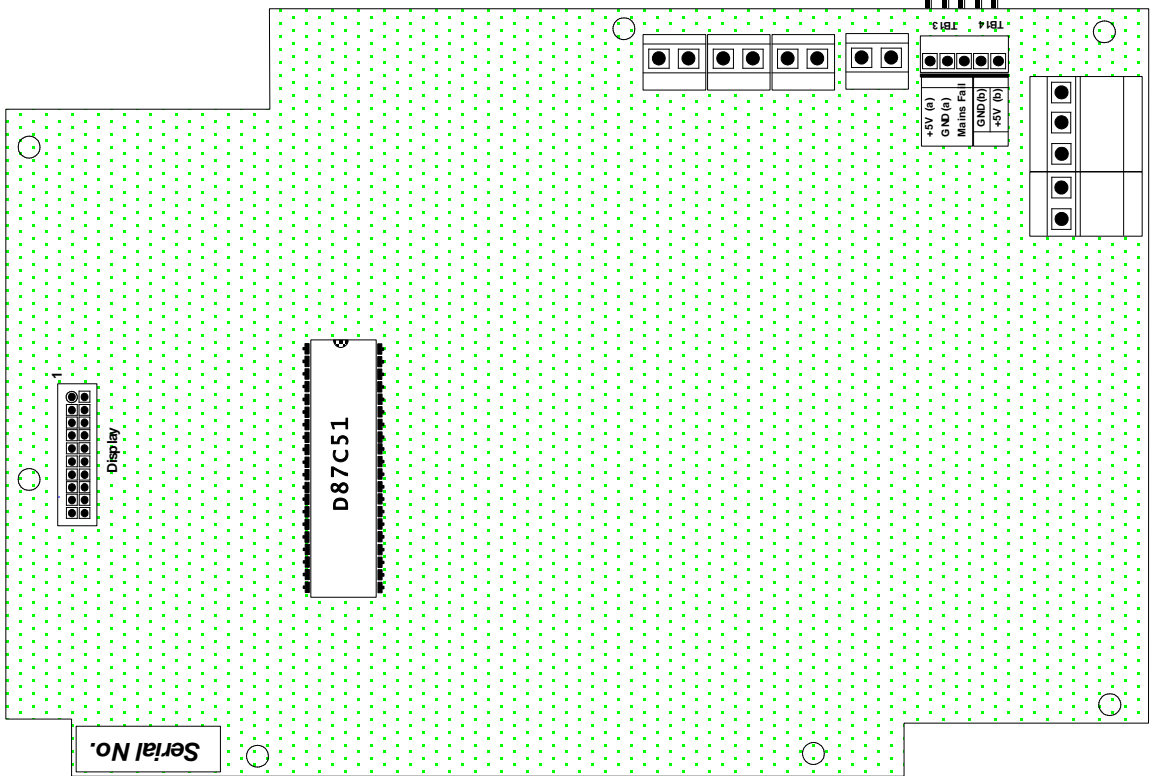
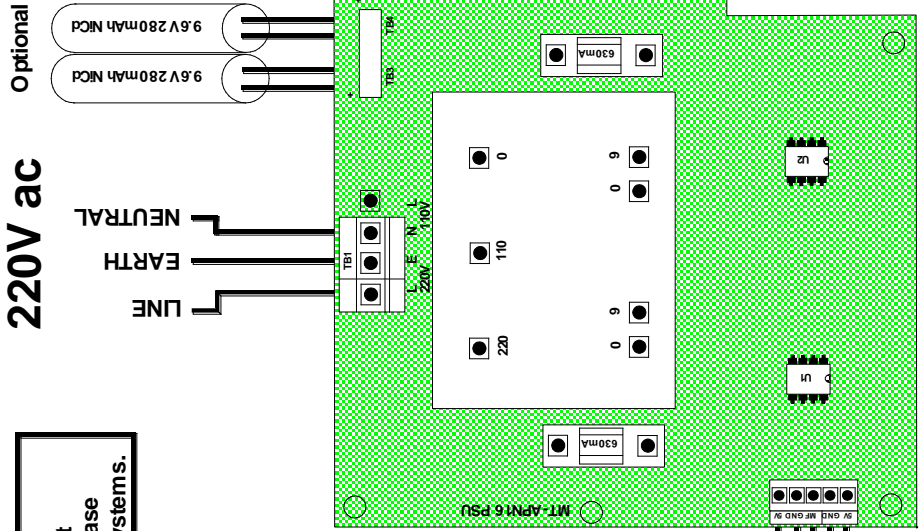



# **SPECIFICATIONS**

## **POWER SUPPLY**

- 110/220 Volt ac supply with max 20% tolerance.
- Surge suppressers- 275V.
- Dual 9 Volt ac/12 Volt DC 500mA input (optional).
- Dual 9.6V 280mAh Ni-Cad standby batteries (optional).
- Dual 5V DC 400mA outputs.
- Fuses 22mm 630mA glass cartridge.

## **INPUTS**

- 16 inputs.
- Each input is optically isolated.
- Each input requires a voltage-free contact.
- Inputs can be individually configured for Normally Open or Normally Closed operation.
- One common for all inputs.
- Maximum input lead length of 30m.

## **OUTPUT RELAY**

- Normally Open and Normally Closed contacts.
- Voltage-free contacts.
- Contact ratings: 1.5A at 220V ac.  
3A at 24V DC/110V ac.

## **COMMUNICATIONS**

### **ALARM NETWORK**

Interface: Half Duplex RS485.  
Speed: 9600 Baud.  
Distance: 1Km.  
Cable: 2-core 0.22 mylar screen.

### **PC LINK (TRANSMIT ONLY INTERFACE)**

	<u>RS232</u>	<u>RS485</u>
Speed:	9600 Baud.	9600 Baud.
Distance:	30m.	1Km
Cable:	2-core 0.22 mylar screen.	2-core 0.22 mylar screen.
Connector:	9-Way or 25-Way D- Type female.	RS485-PC Interface required

# MT-APN16 Flush Mount Gas Alarm Panel

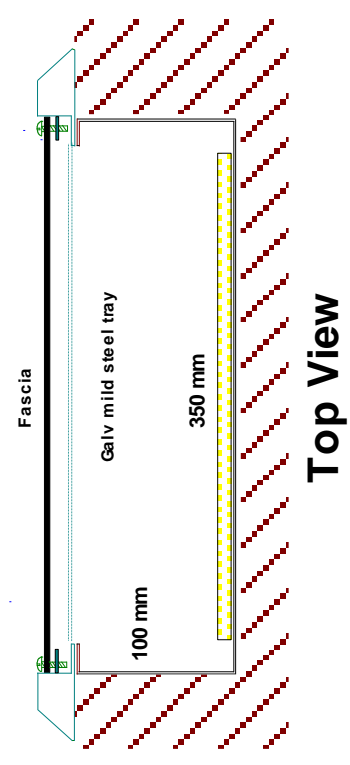
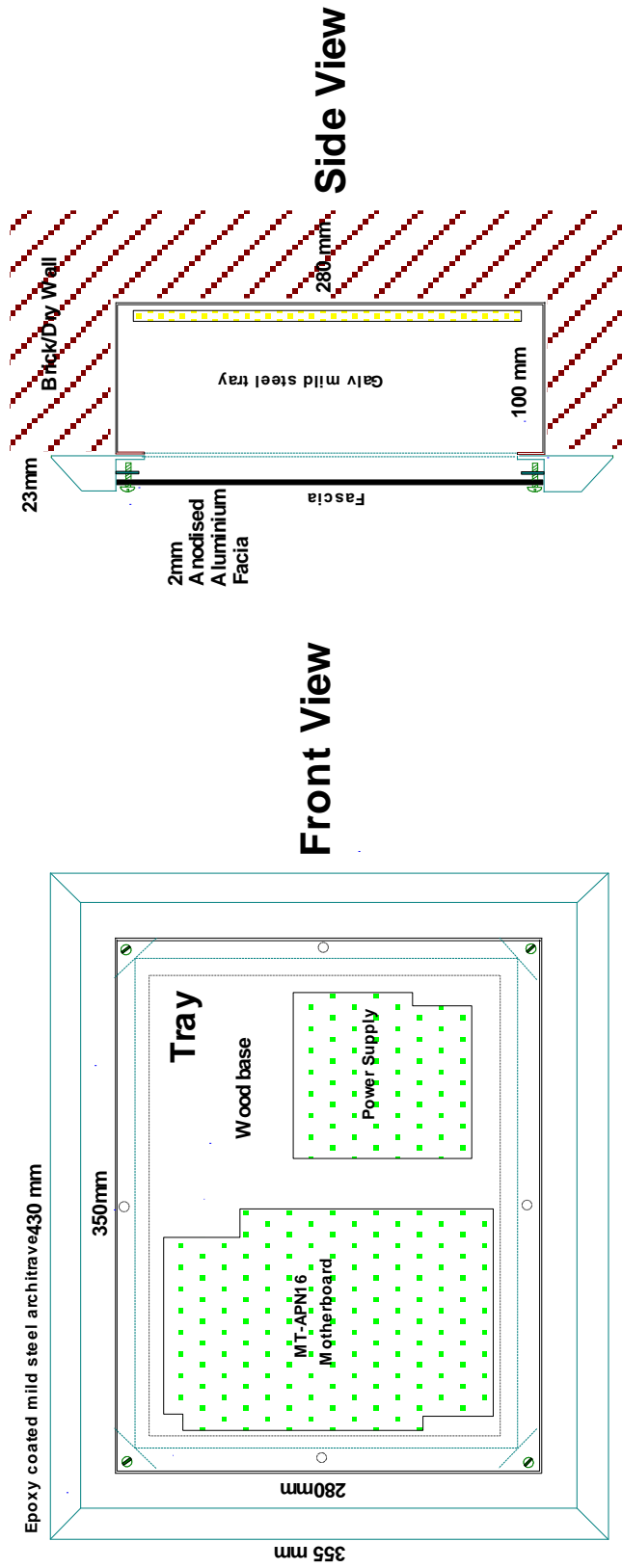

MT-APN15 Flush Mount Panel Physical Dimensions	09/10/2008
MT-APN16 ALARM NETWORK	

# MT-APN16 Surface Mount Gas Alarm Panel

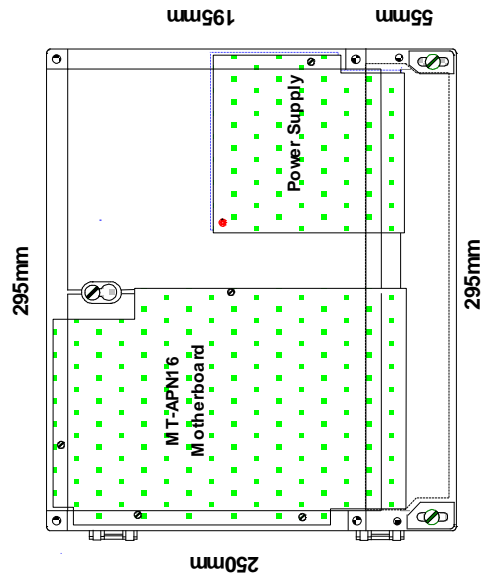

Front View

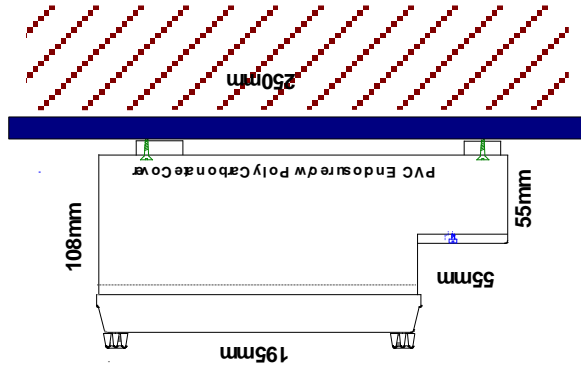

Side View

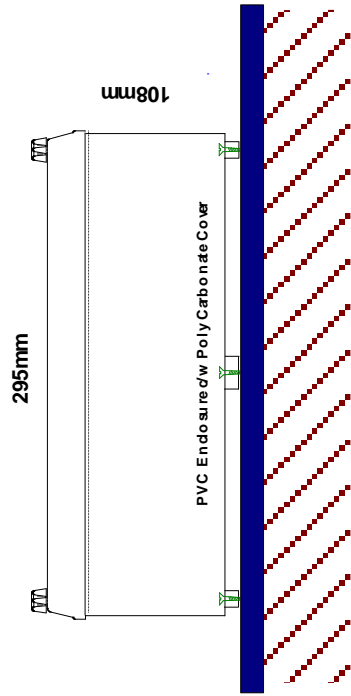

Top View

MT-APN16 Surface Mount Panel Physical Dimensions	08/06/2004
MT-APN16 ALARM NETWORK	

# MT-APN16 Gas Alarm Front Panel Layout

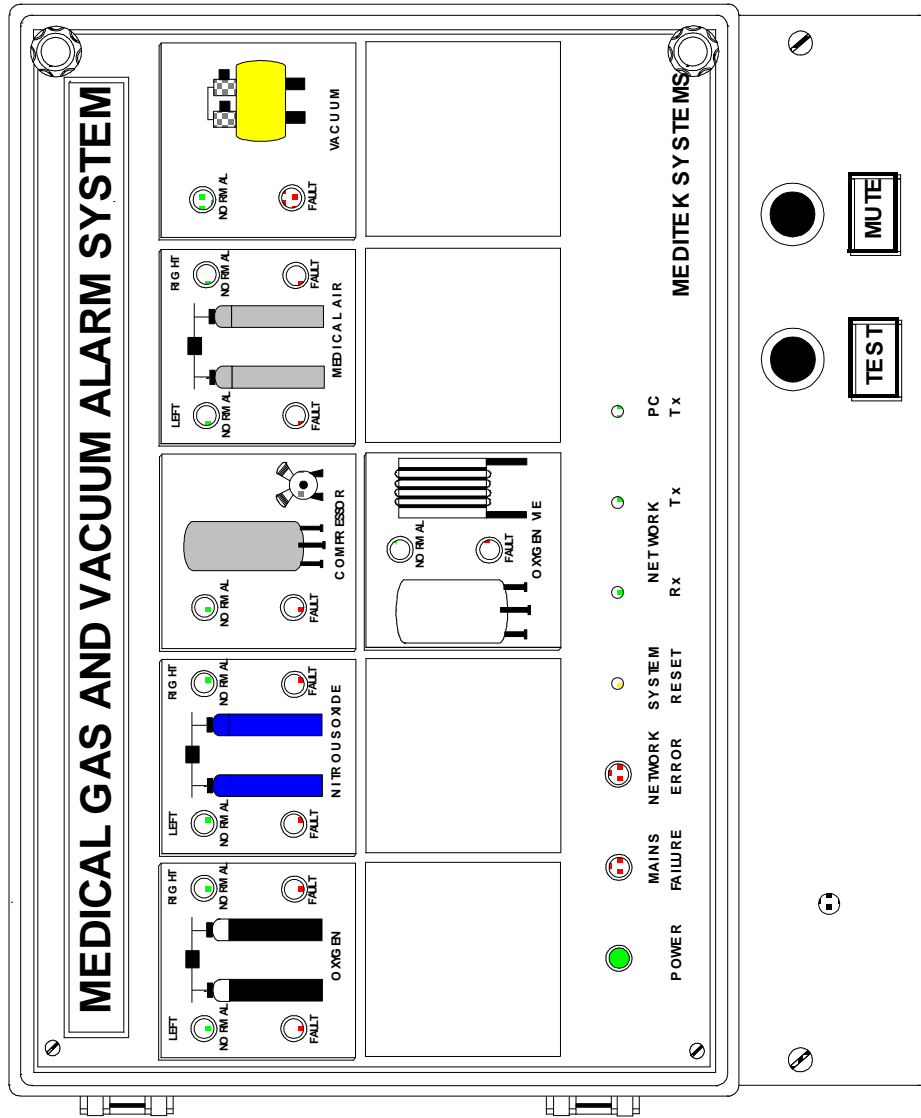

## KEY

<b>POWER</b>	Power LED - Indicates Panel is ON.
<b>MAINS FAILURE</b>	220Vac Main Supply has Failed.
<b>NETWORK ERROR</b>	Problem has occurred with network communications between panels.
<b>SYSTEM RESET</b>	Microprocessor has Reset after a problem caused it to 'Hang-Up'
<b>NETWORK Rx Tx</b>	Panel is Transmitting (Tx) and / or Receiving (Rx) data on the network.
<b>PC Tx</b>	Panel is Transmitting (Tx) data to a Computer (PC) if connected.
<b>TEST</b>	Press to check all lights (LED's) & buzzer.
<b>MUTE</b>	Mute alarm buzz. R emind beep every 30 min.

<b>MT-APN16 Front Panel Layout &amp; description</b>	
<b>MT-APN16 ALARM NETWORK</b>	<b>08/06/2004</b>